

Barrier Support Skids

TOTALSEAL® custom designs support systems to suit the plant design rather than offer a catalogue design.

Our custom designed Barrier Support Skids:

- Circulates barrier fluid through the seal in direct contact with the seal faces.
- This provides direct cooling at the seal faces where frictional heat is generated.
- Traditional systems rely on cooling external to the seal, so the seal faces are not directly cooled.
- Large capacity tank and larger volume charge pumps.
- TotalSeal advantage:
 - In event of a significant leak there is then greater capacity to keep the seals pressurised and cooled.

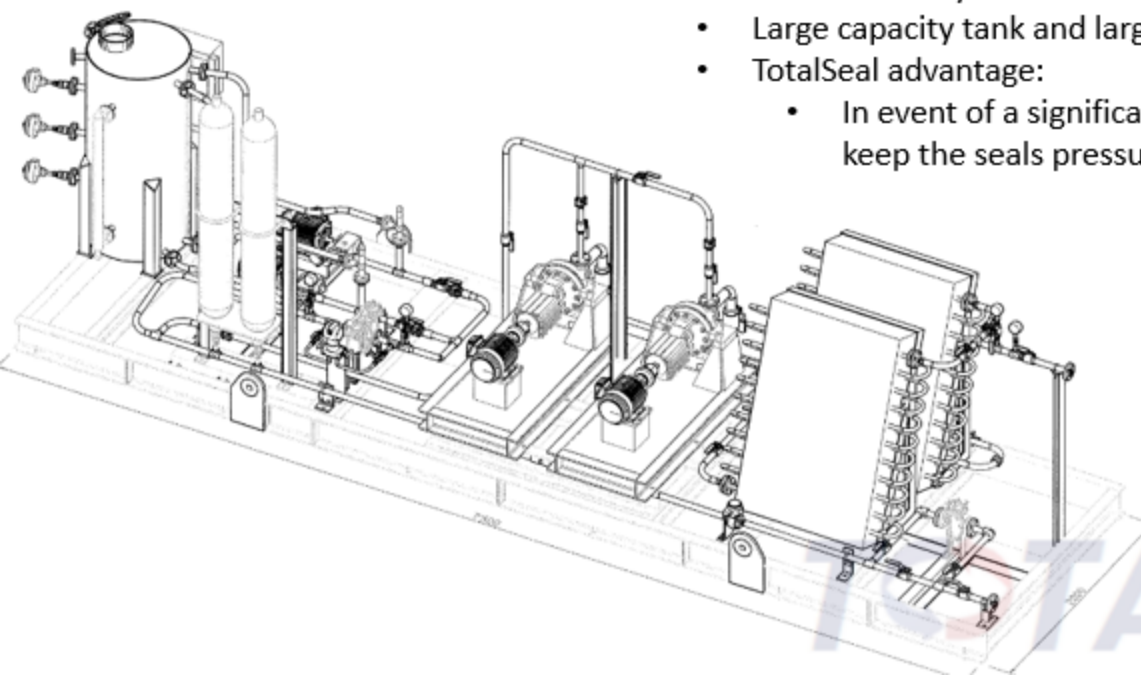

TOTALSEAL®